

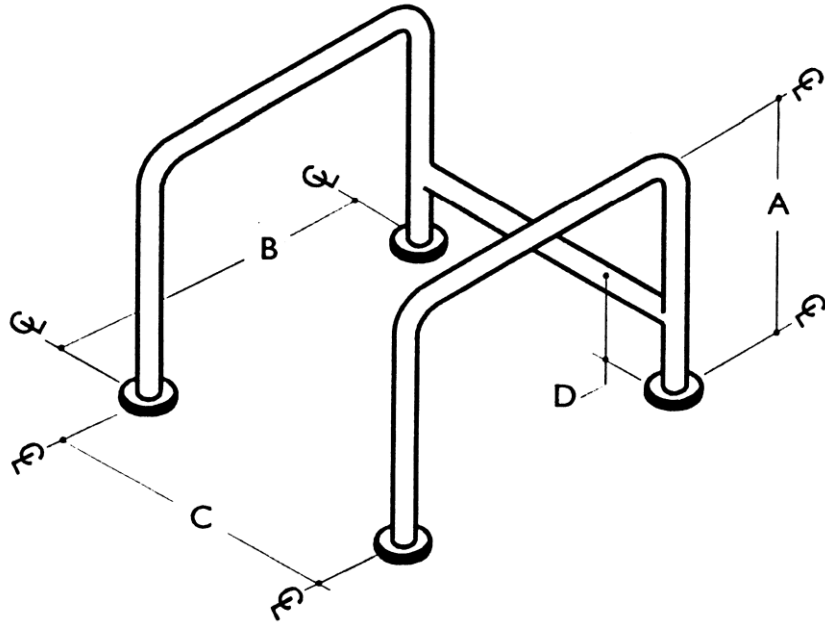

A N C H O R
ARCHITECTURAL PRODUCTS



TYPE Q
DOUBLE STRADDLE RAIL WITH WALL MOUNT

Specify Dimensions A, B, C, D as required

Dimensions are from centerline to centerline of tube and from wall to centerline of tube

CL = Centerline

*Typical Wall clearance is 1.5" (38mm)

QUANTITY	
Bar diameter	
Finish	
Flange style	
Comments:	

PO Box 87855 ~ Carol Stream, IL 60188-7855

Phone 630.372.8280 ~ Fax 630.372.8290

www.anchorarchitectural.com